

# SPECIFICATION

IMAGE FORMAT	1/2.3"
FOCAL LENGTH	15mm
F.O.V.	29°(D)
	23°(H)
	17.5°(V)
RESOLUTION	5MP
DISTORTION	<-1%
APERTURE	F8.0
MOUNT	M9X0.5
IRIS	Fixed
M.O.D.	0.1m
B.F.L.	5.84mm
CONSTRUCTION	4G

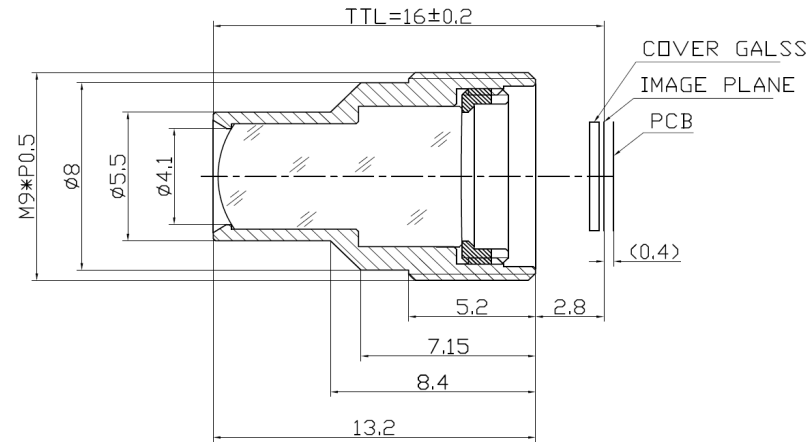

SCALE		DRAWN		MODEL	<b>CCL12315MP</b>	REV	DESCRIPTION	DATE	NAME
DATE		CHECK		 香港致远电子集团有限公司 HONGKONG TOWIN ELECTRONICS CO.,LTD.	①				
UNIT	mm	APPROVE			②				
					③				